

---

**User's  
Manual**

**Model STLD  
(Style E)  
Totalizer**

**YEW SERIES 80**

IM 1B4E4-02E

---

# Notices

## ■ Regarding This User's Manual

- (1) This manual should be passed on the end user. Keep at least one extra copy of the manual in a safe place.
- (2) Read this manual carefully and fully understand how to operate this product before you start operation.
- (3) This manual is intended to describe the functions of this product. Yokogawa Electric Corporation (hereinafter simply referred to as Yokogawa) does not guarantee that the functions will suit a particular purpose of the user.
- (4) Under absolutely no circumstances may the contents of this manual in part or in whole be transcribed or copied without permission.
- (5) The contents of this manual are subject to change without prior notice.
- (6) Every effort has been made to ensure accuracy in the preparation of this manual. Should any error or omissions come to your attention however, please contact your nearest Yokogawa representative or our sales office.

## ■ Regarding Protection, Safety, and Prohibition against Unauthorized Modification

- (1) In order to protect the product and the system controlled by it against damage and ensure its safe use, make certain that all of the instructions and precautions relating to safety contained in this manual are strictly adhered to. Yokogawa does not guarantee safety if products are not handled according to these instructions.
- (2) Be sure to use the spare parts approved by Yokogawa when replacing parts or consumables.
- (3) Modification of the product is strictly prohibited.
- (4) Reverse engineering such as the disassembly or decompilation of software is strictly prohibited.
- (5) No portion of the software supplied by Yokogawa may be transferred, exchanged, leased or sublet for use by any third party without the prior permission of Yokogawa.

## ■ Force Majeure

- (1) Yokogawa does not make any warranties regarding the product except those mentioned in the WARRANTY that is provided separately.
- (2) Yokogawa assumes no liability to any party for any loss or damage, direct or indirect, caused by the user or any unpredictable defect of the product.



## CONTENTS

<i>Section</i>	<i>Title</i>	<i>Page</i>
<b>1.</b>	<b>INTRODUCTION.</b>	1-1
1-1.	Inspection.	1-1
1-2.	Scope of this Manual and Associated Manuals.	1-1
<b>2.</b>	<b>GENERAL.</b>	2-1
2-1.	Standard Specifications.	2-1
2-2.	Model and Suffix Codes.	2-5
2-3.	Options.	2-5
2-4.	Accessories.	2-5
<b>3.</b>	<b>INSTALLATION.</b>	3-1
3-1.	Wiring.	3-1
3-1-1.	Wiring Precautions.	3-2
<b>4.</b>	<b>PRINCIPLES OF OPERATION.</b>	4-1
4-1.	Totalizer Functions.	4-1
<b>5.</b>	<b>OPERATION.</b>	5-1
5-1.	Front- and Side-Panel Features.	5-1
5-1-1.	Front Panel.	5-1
5-1-2.	Instrument Side Panel.	5-2
5-2.	Preparation of Data Label.	5-5
5-3.	Preparation for Operation.	5-5
5-3-1.	Check Special Parts are Installed.	5-5
5-3-2.	Setting Side Panel Switches.	5-5
5-3-3.	Setting Main Data.	5-6
5-3-4.	Setting Auxiliary Data.	5-6
5-3-5.	Simulation.	5-7
5-3-6.	Other Preparations.	5-8
5-4.	Operation.	5-8
5-4-1.	Resetting Totalizer Value.	5-8
5-5.	Actions to be Taken when FAIL Lamp and ALM Lamp Light.	5-8
5-5-1.	Actions to be Taken when FAIL Lamp Lights.	5-8
5-5-2.	Actions to be Taken when ALM Lamp Lights.	5-8
5-5-3.	Actions to be Taken when ALM Lamp Flashes.	5-8
5-5-4.	Alarm (ALM) Codes, their Meanings and Control Actions when Abnormal.	5-9
<b>6.</b>	<b>MAINTENANCE.</b>	6-1
6-1.	Replacing Nameplate.	6-1
6-2.	Replacing Fuse.	6-1
6-3.	Replacing Data Memory Backup Battery.	6-1
●	<b>WORKSHEET</b>	WS1B4E4-02E
●	Customer Maintenance Parts List	CMPL 1B4E3-03E
●	<b>POWER SUPPLY TERMINALS for PANEL-MOUNTED INSTRUMENTS (for/HTB)</b>	IM 1B4F1-11E



## 1. INTRODUCTION.

### 1-1. Inspection.

This instrument was thoroughly tested at the factory before shipment.

However, when you receive this instrument:

- 1) Inspect for visible damage.
- 2) Confirm that the model and suffix codes shown on the shipping documents, and also on the nameplate on the instrument side panel, are the same as on your order sheet.
- 3) Confirm that all accessories (see section 2-4) are present.

If you have any question about this instrument, please contact either your nearest Yokogawa Sales/Service Office or Yokogawa Electric Corporation Tokyo, Japan.

### 1-2. Scope of this Manual and Associated Manuals.

This Instruction Manual covers handling, operating and simple maintenance procedures for the STLD\*E Totalizer.

You should first read the following manuals, in order to fully understand the functions of the STLD\*E Totalizer. You will then be able to fill out the data label on the side panel of the totalizer.

Please refer to the following manuals:

- ① TI 1B4E4-01E  
“Model STLD (Style E) Totalizer Functions and Data Setting”.
- ② WS 1B4E4-02E “STLD\*E Data Sheet”



## 2. GENERAL.

The STLD\*E totalizer is capable of totalizing not only pulse signal inputs from flow transmitter but also analog signal inputs.

The totalizer functions include:

- Scaling, addition or subtraction of flow signals, instantaneous flow display, repeater for a flow signal.
- Analog inputs and outputs, compensation computation, and temperature-pressure compensation computations.
- Various totalizer functions. Totalizer parameters are easy to set, and totalizer totals may be viewed.
- Communications functions — the instrument is easy to design into a system, it can communicate with a central operator station or supervisory computer.
- Self-diagnostic functions.

Figure 2-1-1 shows the front view of STLD\*E.

## 2-1. Standard Specifications

### Input Signals

**Process Variable Pulse Input Signal:** 0 to 6 kHz, zero elevation not possible, minimum pulse width 50  $\mu$ s. Pulse input from two-wire/three-wire transmitter, or voltage transition/contact signal.

**Input From Transmitter:** STLD contains distributor, voltage is switch-selectable — distributor supplies 12 V/24 V  $\pm$ 10%, current up to 50 mA. For two-wire transmitter, load resistance is switch selectable — 200  $\Omega$ , 510  $\Omega$  or 1 k $\Omega$ .

### Voltage (Transition) Pulse:

Voltage LOW Level ( $E_L$ ): -1 V to +8 V DC.

Voltage HIGH Level ( $E_H$ ): 3 V to 24 V DC.

Amplitude of Pulse Signal ( $E_H - E_L$ ): At least 3 V.

Input Resistance: At least 10 k $\Omega$ .

**Contact Pulse:** Relay/switch contact or transistor switch.

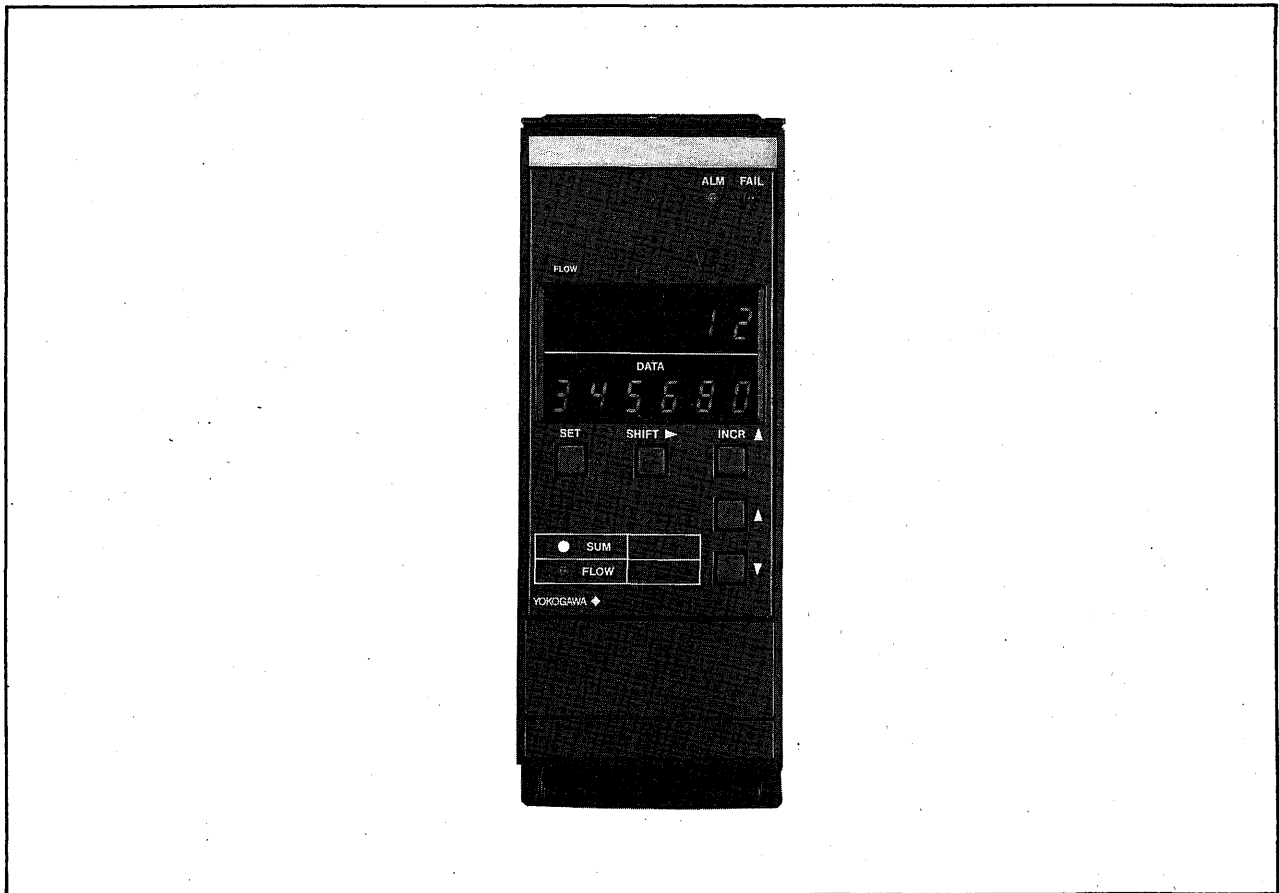

Figure 2-2-1. Front View of STLD\*E.



Contact ON: Source resistance up to 200  $\Omega$ .  
 Contact OFF: Source resistance at least 100 k $\Omega$ .  
 Contact Rating: At least 30 V DC, 30 mA.  
**Filter for Contact Pulse Input:** Switch-selectable, time constant 10 ms.

**Auxiliary Pulse Input Signal (Added to/Subtracted from Process Variable), and Status Contact Inputs:**

Auxiliary pulse input is 0 to 1 kHz, zero elevation not possible, minimum pulse width 350  $\mu$ s. Status input minimum pulse width 220 ms. Voltage (level) or contact signals.

**Voltage (Level) Input:**

Voltage LOW Level ( $E_L$ ): -1 V to +1 V DC (status ON).

Voltage HIGH Level ( $E_H$ ): 4.5 V to 25 V DC (status OFF).

**Contact Input:** Relay/switch contact or transistor switch.

Contact (Status) ON: Source resistance up to 200  $\Omega$ .

Contact (Status) OFF: Source resistance at least 100 k $\Omega$ .

Contact Rating: At least 5 V DC, 20 mA.

**Analog Input Signals (Process Variable or Auxiliary Flow and Compensation Signals):** (STLD-201 and -301 only): 1 to 5 V DC, input resistance 1 M $\Omega$ .

**Analog Input Conversion Accuracy:**  $\pm 0.2\%$  of span.

**RTD Input Signal (for Temperature Compensation):** (STLD-301 only): JIS or DIN specification Pt 100  $\Omega$  3-wire RTD, lead wire resistance up to 10  $\Omega$ /wire.

**Temperature Compensation Accuracy:**  $\pm 0.2\%$  of span.

**Burnout Function:** Provided; scaleout time up to 60 s.

**Output Signals**

**Pulse Output Signal (Flow Repeater Signal):** Transistor contact signal, rating 30 V DC, 200 mA.

**Frequency:** 0 to 1 kHz; **Duty Cycle** 50% (for connecting to YewSeries BCS Instrument), or **Fixed Pulse Width** - selectable (one of 0.5, 1, 20, 33, 50 or 100 ms) - for electromechanical counter.

**Fail Output Signal:** Transistor contact signal, rating 30 V DC, 200 mA.

**Analog Output Signal (Flow Repeater Signal):** 1 to 5 V DC, load resistance at least 2 k $\Omega$ .

**Analog Output Conversion Accuracy:**  $\pm 0.3\%$  of span.

**Isolation**

Contact (pulse/status) I/O signals are isolated from internal circuitry; analog signals are not. Pulse I/O signals are isolated from each other; status inputs, status outputs and analog I/O signals use separate common negative lines. Power supply is isolated from internal circuitry.

**Input Processing Functions**

Process variable and auxiliary flow inputs may be either voltage or pulse signals, compensation input may be either a voltage or RTD signal.

**Auxiliary Flow Signal Processing:** (STLD-201 and -301 only):

Auxiliary flow signal can be added to or subtracted from process variable signal. Range of analog output (to display and repeater) is adjustable.

IM 1B4E4-02E

**Voltage Flow Signal Processing:** Span setting (4-digit fixed point number) corresponding to input signal range of 1 to 5 V DC; low-input cutoff (for inputs under 1% of span) and square root function selectable.

**Input Filters (for Process Variable Pulse Input and Auxiliary Pulse Input):** First order lag filters, time constant adjustable 0 to 9999 s.

**Totalizer Scale Factors:** Scaler for pulse signal input (constant K number of pulses for every flow unit totalized). Totalizer scale factor for analog signal input. K ( $K_1$ ,  $K_2$ ) are 5-digit fixed point numbers, of maximum value 32767.

**Compensation Computations (STLD-201 and -301 only)**

Can compensate the process variable and auxiliary flow signals for liquid density changes with temperature. STLD has the following 4 ASTM compensation.

- Old ASTM No. D1250 (edit in 1952)
- New ASTM No. D1250 (edit in 1980) for crude oils, fuels & solvents and lubricating oils.

Other types of compensation are also possible (see below). For temperature or temperature-pressure compensation, temperature unit is selectable ( $^{\circ}$ C or  $^{\circ}$ F).

**Temperature Compensation:**

Input Signal: Platinum RTD JIS '89 JPt 100 or JIS '89 Pt 100 (DIN Pt 100) or 1 to 5 V DC.

Temperature Range: For platinum RTD; -50 to +250 $^{\circ}$ C.

For a 1 to 5 V DC signal: Arbitrary.

Computation Format: ASTM equation or general quadratic equation.

ASTM Equation:  $V_0 = V [(1 + \alpha) \cdot f(\rho, t)]$

where  $f(\rho, t) = VCF$

$$VCF = \frac{V_{15}}{V_t} = \frac{\rho_t}{\rho_{15}}$$

$$= \exp [-\alpha\gamma\Delta t (1.0 + 0.8 \alpha\gamma\Delta t)]$$

where  $VCF$  : Volume conversion coefficient (at 15 $^{\circ}$ C)

$V_{15}$  : Volume ( $m^3$ ) at 15 $^{\circ}$ C

$V_t$  : Volume ( $m^3$ ) at arbitrary temperature ( $t^{\circ}$ C)

$\rho_t$  : Density ( $t^{\circ}$ C) ( $kg/m^3$ )

$\rho_{15}$  : Density (15 $^{\circ}$ C) ( $kg/m^3$ )

$\alpha\gamma$  : Thermal expansion coefficient at 15 $^{\circ}$ C ( $^{\circ}$ C $^{-1}$ )

$\Delta t$  : Temperature difference [ $\Delta t = t - 15$ ] ( $^{\circ}$ C)

**General Quadratic Equation:**

$$V_0 = V [(1 + \alpha) \{1 + \beta(t - t_0) \times 10^{-2} + \gamma(t - t_0)^2 \times 10^{-6}\}]$$

$V_0$ : Volumetric flow at reference temperature  $t_0$ .

$V$ : Volumetric flow (process variable flow signal) at temperature  $t$ .

$t_0$ : Reference temperature ( $^{\circ}$ C),  $t_0 = 15^{\circ}$ C for ASTM.

- t: Flow sensor temperature (°C).
- α: Flow transmitter compensation coefficient, (-99.99 to +99.99).
- β: First order compensation coefficient, (-99.99 to +99.99).
- γ: Second order compensation coefficient, (-99.99 to +99.99).

**Temperature-Pressure Compensation Computation:**  
 Input Signal: Platinum RTD JIS '89 JPt 100 or JIS '89 Pt 100 (DIN Pt 100) or 1 to 5 V DC.  
 Temperature Range: For Pt RTD; -50 to 250°C.  
 For 1 to 5 V signal: Arbitrary.  
 Pressure signal: 1 to 5 V DC

$$Q_T = N \cdot \frac{1}{K_F} \cdot k$$

$$Q_R = f \cdot \frac{1}{K_F} \cdot k \cdot R_t$$

In the above equations, the compensation coefficient k may be as follows:

- (1) For Natural Gas: Compensation according to AGA Report No.3/NX-19.  
 Compensation range: Pressure; 0 to 13.7 MPa G. (0 to 140 kgf/cm<sup>2</sup> G)  
 Temperature; -40 to 115°C  
 Specific gravity; 0.554 to 0.750, N<sub>2</sub> and CO<sub>2</sub> mol %; 0 to 15%

$$k = \frac{P}{P_b} \cdot \frac{T_b}{T} \cdot (F_{PV})^2$$

- (2) For Steam: Compensation by IFC Formula for Industry (Steam Tables, 1967).  
 Compensation range:  
 Pressure; 0.1 to 9.8 MPa abs. (1 to 100 kgf/cm<sup>2</sup> abs)  
 Temperature; 100 to 400°C  
 Specific weight; 0.1 to 100 kg/m<sup>3</sup>  
 Specific enthalpy; 2520 to 3340 kJ/kg (600 to 800 kcal/kg)

For steam, instead of obtaining compensation coefficient, the specific weight and specific enthalpy is obtained by the formula shown above to calculate weight and heat flows.

$$W = Q \cdot \gamma$$

$$H = Q \cdot \gamma \cdot h = W \cdot h$$

- (3) General Gas: To compensate for the deviation from ideal gas behaviour,  
 Compensation range: Pressure; 0 to 13.7 MPa abs. (0 to 140 kgf/cm<sup>2</sup> abs).  
 Temperature; -40 to 400°C  
 Ratio of critical pressure to pressure; 0.01 to 30.0, and ratio of critical temperature to temperature; 0.60 to 15.0  
 Critical compressibility factor: 0.25 to 0.30

$$k = \frac{P}{P_b} \cdot \frac{T_b}{T} \cdot \frac{1}{K}$$

$$K = \frac{Z}{Z_b}$$

K can either be set manually, or the ratio Z/Z<sub>b</sub> can be entered to derive K (compressibility factors Z and Z<sub>b</sub> are obtained from Z tables).  
 where,

- Q<sub>T</sub>: Totalizer volumetric flow
- Q<sub>R</sub>: Instantaneous volumetric flow
- Q: Steam volumetric flow
- k: Compensation coefficient
- K<sub>F</sub>: Flowmeter K-factor
- K: Gas deviation coefficient
- N: Number of input pulses
- f: Frequency
- R<sub>t</sub>: Flow unit time
- P: Fluid pressure
- P<sub>b</sub>: Reference pressure
- T: Fluid temperature
- T<sub>b</sub>: Reference temperature
- F<sub>PV</sub>: Natural gas supercompressibility factor
- W: Steam weight flow
- H: Steam heat flow
- h: Specific enthalpy
- γ: Steam specific weight

**General Compensation Computations:**

Computation Format:  $V_o = V [(C_{max} - C_{min}) C + C_{min}]$ ,  
 C ranges from 0 to 1 - its value corresponds to the compensation input signal: a voltage in the range 1 to 5 V DC. C<sub>max</sub> and C<sub>min</sub> are maximum and minimum compensation coefficients respectively, and may be set independently in the range 0 to 9999.

**Flow Signal Repeater Function**

Outputs pulse and analog\* signals corresponding to the flow signal process variable input (the instrument can also add or subtract an auxiliary flow signal input - in this case, the span of analog output (to display and repeater) is adjustable).

\* (STLD-201 and -301 only).

**Pulse Output:** Output pulse rate may be scaled by a factor K'. K' (K<sub>3</sub>, K<sub>4</sub>) are 5-digit fixed point numbers, of maximum value 32767.

**Pulse Output ON Time:** Selectable - one of 0.5, 1, 20, 33, 50 or 100 ms - or duty cycle of 50% (for YewSeries BCS Instruments; up to ten may be connected in parallel with output).

**Analog Output (Flow Signal Repeater Signal):** 1 to 5 V DC.

**Totalizer Functions**

Five 8-digit totalizers are built in - three flow totalizers and two (cumulative) totalizers:

- Flow totalizer (process variable only).
- Flow totalizer (process variable, with compensation computation).
- Flow totalizer (process variable, with auxiliary flow signal added to or subtracted from it, and compensation computation).
- Cumulative flow totalizer (process variable, with auxiliary flow signal added to or subtracted from it).
- Cumulative flow totalizer (process variable, with auxiliary flow signal added to or subtracted from it, and compensation computation).

Flow totalizer is reset by reset input signal or by data entry. Cumulative flow totalizer may be reset manually by entering other data for totalizer value.

**Data Display and Data Setting Functions**

**Data Display:**

Upper display is the most significant two digits of totalizer, 6 digits.

Lower display is selectable data, 6 digits.

Selectable data (displayed in lower display) may be major data item or auxiliary data item:

**Major Data Item:** Displayed data type is indicated by lamp next to data item label on front panel. Value of flow totalizer (for process variable with auxiliary flow signal added to or subtracted from it, and compensation computation), instantaneous flow may be displayed.

**Auxiliary Data Item:** Displayed data type is indicated by code displayed in upper display. Auxiliary data includes the other four totalizer values, and compensation parameters. A table of data that may be displayed is on the instrument side panel.

**Instantaneous Flow Display:** 5-segment bar graph.

**Data Setting:**

**Displayed Data Selection:** Selected by push buttons.

One switch (on side panel) changes from major data display to auxiliary data display.

**Data Setting:** Uses push button switches. Data setting may be inhibited (disabled) by an inhibit/enable switch on the side panel.

**Communication Functions**

The STLD can communicate (via LCS card in field control station/unit) with a central  $\mu$ XL/CENTUM CRT-display operator station and supervisory computer. Maximum length of (SCCD) cable to LCS card is 100 m (328 ft).

**Data Transmitted:** Instantaneous flow, flow totalizer value (process variable, with auxiliary flow signal added to or subtracted from it, and compensation computation), control mode, compensation coefficients etc.

**Data with Remote Setting:** Flow totalizer value (process variable, with auxiliary flow signal added to or subtracted from it, and compensation computation), compensation coefficients etc. Remote setting (from  $\mu$ XL/CENTUM operator station or supervisory computer) can be disabled by "C/A" switch on side panel.

**Mounting:**

Flush panel mounting. Instruments are in housings, and may be mounted individually or side-by-side.

Rear of instrument may be up to 75° below front (indicator zero may need readjustment).

**Wiring:**

**Signal Wiring to/from the Field:** ISO M4 size (4 mm) screws on terminal block.

**Power and Ground Wiring:**

100 V version: JIS C 8303 two-pin plug with earthing contact. (IEC A5-15, UL498).

220 V version: CEE 7 VII (CENELEC standard) plug.

Power Cable Length: 30 cm (11.8 in).

**Front Panel Finish:** Dark green (Munsell 2.5GY 3/1).

**Bezel:** Aluminium diecast, black baked-enamel finish.

**Housing:** Open front.

**Housing Dimensions:** 182.5 (H) × 87 (W) × 480 (D: depth behind panel) (mm) (7.2 × 3.4 × 18.9 in).

**Weight:**

Instrument body: 3.1 kg (6.8 lb) (excluding housing).

Housing: 2 kg (4.4 lb) (excluding mounting kit).

**Normal Operating Conditions**

**Ambient Temperature:** 0 to 50°C (32 to 122°F).

**Ambient Humidity:** 5 to 90% Relative Humidity (non-condensing).

**Power Supply:** Two versions, for "100 V" (standard) or "220 V" (option /A2ER). Both versions may use AC or DC, without change to the instrument:

Version	"100V"	"220V"
DC (polarity reversible)	20 to 130V	120 to 340V
AC (47 to 63Hz)	80 to 138V	138 to 264V

**2-2. Model and Suffix Codes**

Model	Suffix codes	Style	Option codes	Description
STLD	.....	.....	.....	Totalizer with communication functions
Compensation Input, Analog I/O	-1 .....	.....	.....	No compensation input, no analog I/O
	-2 .....	.....	.....	1 to 5V DC } compensation input; also analog I/O
	-3 .....	.....	.....	
		01 .....	.....	Always 01
Style Code		*E .....	.....	Style E
Option			/DL	With data labels attached
Common Options			/A2ER /PA /PD  /MTS /SCF- G□M /NHS /NPE	220V power supply <sup>(1)</sup> JIS '89 JPt 100 <sup>(2)</sup> JIS '89 Pt 100 (DIN Pt 100) <sup>(2)</sup> With mounting kit Bezel color change  Without housing Nameplate engraving

(1) When ordering housing separately, specify /A2/NHS.

(2) Specify only compensation input RTD.

### 2-3. Options

- /DL: With data set as per data sheet, and corresponding data label attached.
- /A2ER: For "220 V version" power supply.
- /PA: Compensation input JIS '89 JPt 100.
- /PD: Compensation input JIS '89 Pt 100.
- /MTS: Supplied with kit for individual mounting.  
For mounting in groups, see GS 1B4F1-E.
- /SCF-G□M: Mounting kit bezel color change from standard color (black). Choose color from set of optional colors (see GS 22D1F1-E). Specify color code in space □.
- /NHS: No housing, plug-in instrument module only.  
See GS 1B4F1-E to order housing separately.
- /NPE: Letters engraved on front panel nameplate.

### 2-4. Accessories

- |   |                   |
|---|-------------------|
| 1A fuse, quantity one                       | Part No.: S9510VK |
| Engineering units label, one set.           | Part No.: E9712DL |
| Blank label, one set.<br>(for user filling) | Part No.: E9712DS |

Note: The fuse (S9510VK) is the dedicated fuse, Do not use it for other products.



### 3. INSTALLATION.

For general information regarding installation of this instrument, refer to the instruction manual "Installation of Panel-Mounting Instruments" (IM 1B4F1-01E).

#### 3-1. Wiring.

The terminal board is located on the rear of the housing. Remove the cover of the terminal board, and connect external signal wires to the (M4 size) screw terminals. After wiring, be sure to replace the cover. (See Figures 3-1-1 and 3-1-2.)

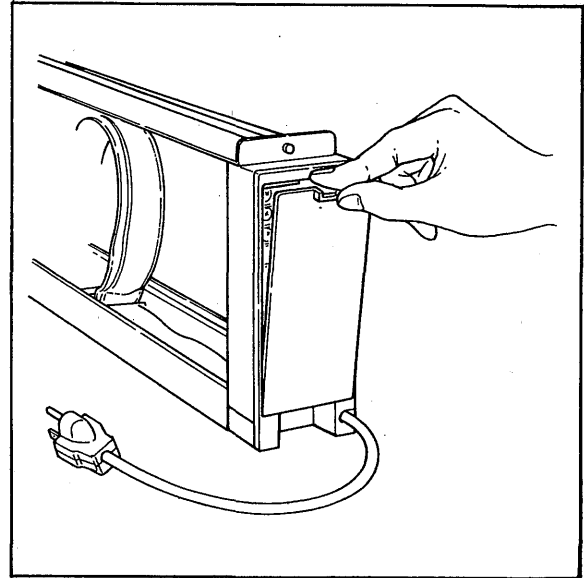

Figure 3-1-2. Terminal Cover.

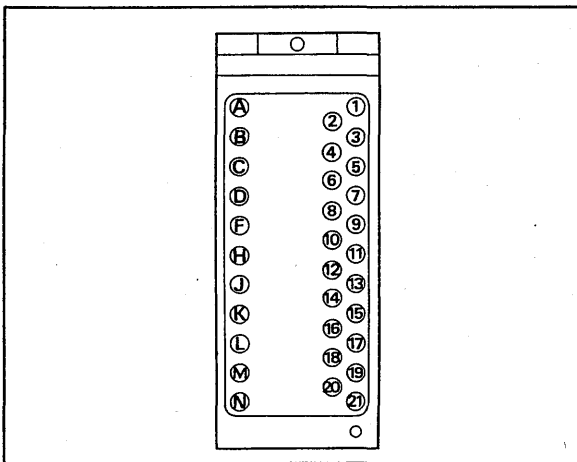

Figure 3-1-1. Terminal Layout.

Table 3-1-1, 3-1-2 and 3-1-3 show the terminal designations and signals to be connected for the STLD-101\*E through STLD-301\*E versions of the totalizer.

#### ■ Terminal Wiring

Table 3-1-1. STLD-101\*E.

Terminal Designation	Description	Terminal Designation	Description
1	Process variable input, pulse signal *1	17	Communications *2
2		18	
3		19	Auxiliary pulse flow signal input
4		20	
5		21	Fail output (- terminal)
6		A	Flow signal repeater (pulse output)
7		B	
8		C	
9		D	
10		F	Fail output (+ terminal)
11	H		
12	J		
13	K		
14	L		
15	M		
16	N		

Note 1: Change wire connection according to the type of transmitter used. (See Sections 5-1-2 and 5-3-2).

Terminal Designation	Contact or Voltage Level Pulse*	2-wire Type Power Supply**	3-wire Type Power Supply**
1	Transmitter	Transmitter	Transmitter
2			
3			

\* Voltage level pulse: external distributor.

\*\* 12V/24V distributor for transmitter built into STLD.

Note 2: Use shielded twisted-pair cable (SCCD see GS 34B6T1-01E).

Table 3-1-2. STLD-201\*E.

Terminal Designation	Description	Terminal Designation	Description
1	Process variable input, pulse signal *1	17	+ Communications *2
2		18	- Communications *2
3		19	+ Auxiliary pulse flow signal input
4	Compensation input, 1 to 5 V DC	20	- Auxiliary pulse flow signal input
5		21	- Fail output (- terminal)
6	Process variable input, or auxiliary flow input, 1 to 5 V DC	A	Flow signal repeater (pulse output)
7		B	
8	Analog compensation input (pressure signal)	C	+ Flow signal repeater (pulse output)
9		D	
10	Reset input	F	Flow signal repeater (1 to 5 V output)
11		H	
12	Reset input	J	+ Flow signal repeater (1 to 5 V output)
13		K	
14		L	
15		M	
16		N	+ Fail output (+ terminal)

Notes 1 and 2: Refer to previous page.

Table 3-1-3. STLD-301\*E.

Terminal Designation	Description	Terminal Designation	Description
1	Process variable input, pulse signal *1	17	+ Communications *2
2		18	- Communications *2
3		19	+ Auxiliary pulse flow signal input
4	RTD input	20	- Auxiliary pulse flow signal input
5		21	- Fail output (- terminal)
6	Process variable input, or auxiliary flow input, 1 to 5 V DC	A	Flow signal repeater (pulse output)
7		B	
8	Analog compensation input (pressure signal)	C	+ Flow signal repeater (pulse output)
9		D	
10	Reset input	F	Flow signal repeater (1 to 5 V output)
11		H	
12	Reset input	J	+ Flow signal repeater (1 to 5 V output)
13		K	
14		L	
15		M	
16		N	+ Fail output (+ terminal)

Notes 1 and 2: Refer to previous page.

**3-1-1. Wiring Precautions.**

- (1) Be sure to terminate all cable connections in solderless crimp-on lugs.
- (2) Each status and voltage input must be as per STLD\*E specifications. Note the limits on conductor resistance, voltage drop in conductors, and voltage (high/low) levels. (Refer to Section 2-1. Standard Specifications)
- (3) The fail and digital outputs are transistor contact signals (isolated from power supply and other internal circuitry). When connecting external devices, pay attention to the following: (See Figure 3-1-3.)

- Observe correct polarity of status output terminals.

- Most status outputs share a common negative terminal.
  - When connecting a relay or other such inductive device, connect a surge absorber (protective diode - Figure 3-1-3, CR circuit, etc.) in parallel with the load.
  - Note that status outputs cannot be connected directly to an AC circuit. Use a relay to switch an AC circuit.
  - Do not connect any load which exceeds the contact rating. (Max. 30V DC, 200 mA).
- (4) Use shielded twisted-pair SCCD cable for communication lines (terminals 17, 18).

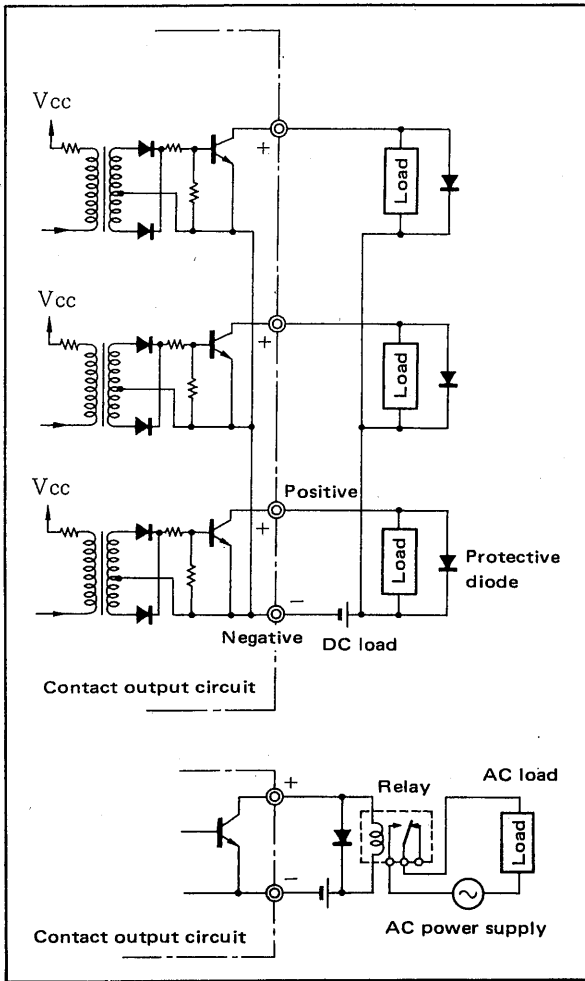

Figure 3-1-3. Connection of Contact Outputs.





### 4. PRINCIPLES OF OPERATION.

This chapter outlines some major features of the STLD\*E Totalizer that are used daily in operating the system. For further details, read TI 1B4E4-01E "Model STLD (Style E) Totalizer Functions and Data Setting". (2nd Edition or later).

Refer to the STLD\*E functional block diagram in Figure 4-1-1.

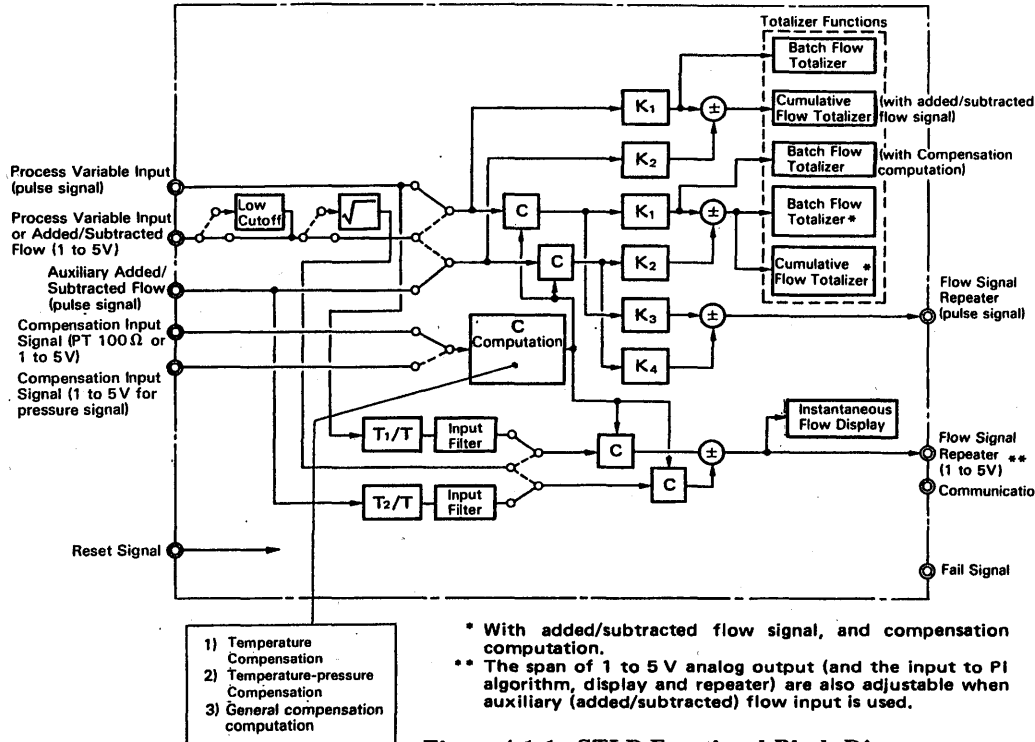

	Pulse input	1 to 5V input
K <sub>1</sub>	$\frac{1}{K \text{ factor for flow process variable}}$	$\frac{\text{Flow process variable span} \times \text{Totalizer scale factor}}{\text{day or h or min}}$
K <sub>2</sub>	$\frac{1}{K \text{ factor for added/subtracted flow}}$	$\frac{\text{Added/subtracted flow span} \times \text{Totalizer scale factor}}{\text{day or h or min}}$
K <sub>3</sub>	$\frac{\text{Repeater pulse K factor}}{\text{Flow process variable K factor}}$	$\frac{\text{Flow process variable span} \times \text{Totalizer scale factor} \times \text{Repeater pulse K factor}}{\text{day or h or min}}$
K <sub>4</sub>	$\frac{\text{Repeater pulse K factor}}{K \text{ factor for added/subtracted flow}}$	$\frac{\text{Added/subtracted flow span} \times \text{Totalizer scale factor} \times \text{Repeater pulse K factor}}{\text{day or h or min}}$
T <sub>1</sub>	day or h or min	
T <sub>2</sub>	$\frac{\text{Flow process variable span}}{\text{Totalizer scale factor} \times \text{K factor for flow process variable}}$	
T	Period of input pulse	
C	Compensation computation	

Figure 4-1-1. STLD Functional Block Diagram.

#### 4-1. Totalizer Functions.

Totalizers are essential in Batch-Blending Control. The STLD\*E permits the following five totalized values to be displayed. (See Figure 4-1-1.)

- (1) Flow totalizer (process variable only)  
Totalized value of uncompensated flow process variable signal.
- (2) Flow totalizer (process variable, with compensation computation)  
Totalized value of compensated flow process variable signal.
- (3) Flow totalizer (process variable, with auxiliary flow signal added to or subtracted from it, and compensation computation)  
Totalized value of flow process variable after addition/subtraction of auxiliary input and compensation.
- (4) Cumulative flow totalizer value (with added/subtracted flow signal)  
Cumulative totalizer value for uncompensated flow process variable after addition/subtraction of auxiliary input.

- (5) Cumulative flow totalizer value (with added/subtracted flow signal and compensation computation)

Cumulative totalizer value for flow process variable after addition/subtraction of auxiliary input and compensation.

The totalized values are classified into two types; flow totalizers are reset by the reset input signal or by data entry. Cumulative flow totalizers may be reset manually by entering other data for totalizer value.

The totalizer values are eight digits long and are displayed using the upper and lower sections of the display.

Of these five totalizer values, the flow totalizer — with auxiliary flow signal added to or subtracted from it, and compensation computation — is displayed as main data (the item SUM on front panel), and the other four totalizer values may be displayed as auxiliary data.



5. OPERATION.

5-1. Front- and Side-Panel Features.

5-1-1. Front Panel

Figure 5-1-1 shows the front panel.

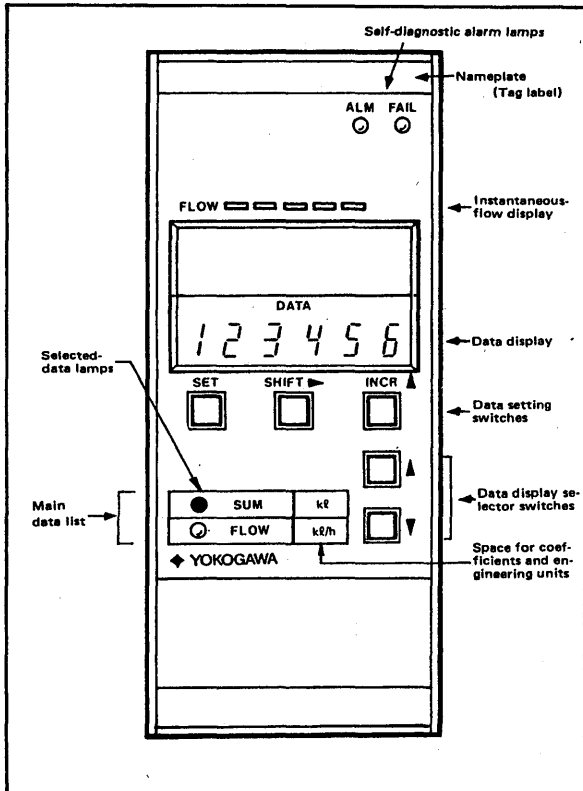

Figure 5-1-1. Front Panel.

- (1) Self-diagnostic alarm lamps.  
 FAIL lamp (red): Lights if the instrument fails.  
 ALM lamp (yellow): Lights to indicate alarm status.

This lamp flashes if the data memory backup battery is not installed, or when its voltage is low.

- (2) Instantaneous flow display.  
 The instantaneous flow is displayed on bargraph consisting of five LEDs.

- (3) Data display  
 The data display is divided into two sections, upper and lower, each of which displays six digits. Frequently-used "main data" (data items — such as compensated flow totalizer and instantaneous flow — shown in the main data list on the front panel), and "auxiliary data" (data items — such as computational constants — shown on the side panel data label) are displayed on this data display according to the setting of the main data/auxiliary data selector switch (FRONT P./SIDE P.) located on the side panel. (See item (6) of par. 5-1-2.)

During ordinary operation, set this selector switch to FRONT P. (main data). With this "main data" setting, the upper section of the display contains the two most significant digits, and the lower section contains the least significant digits. The data item selected using the data display selector switches  $\blacktriangle$   $\blacktriangledown$ . A selected-data lamp lights to indicate which data item is selected. (See Figure 5-1-2.)

To display auxiliary data items, set the FRONT P./SIDE P. selector switch to SIDE P. (auxiliary data). With this setting, the upper section of the display contains an auxiliary data item no., and the lower section contains the corresponding data. The desired item no. is selected using the data display selector switches  $\blacktriangle$   $\blacktriangledown$ . (See Figure 5-1-3.)

The lower data display section can be used for displaying data, and also for setting computational constants.

- (4) Data setting switches (**SET**, **SHIFT**  $\blacktriangleright$ , **INCR**  $\blacktriangle$ ).  
 Used for setting data.

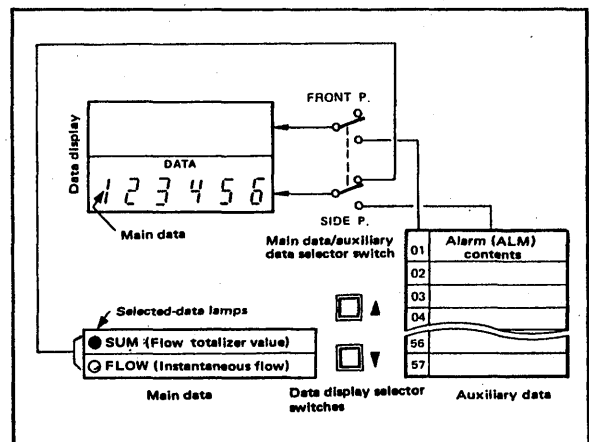

Figure 5-1-2. Functions of Data Display. (Main data display shown.)

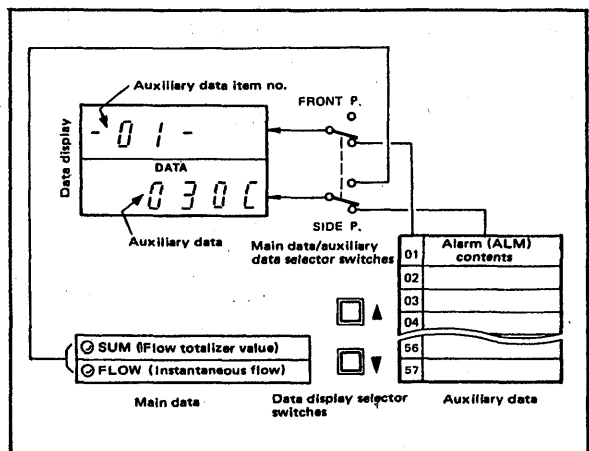
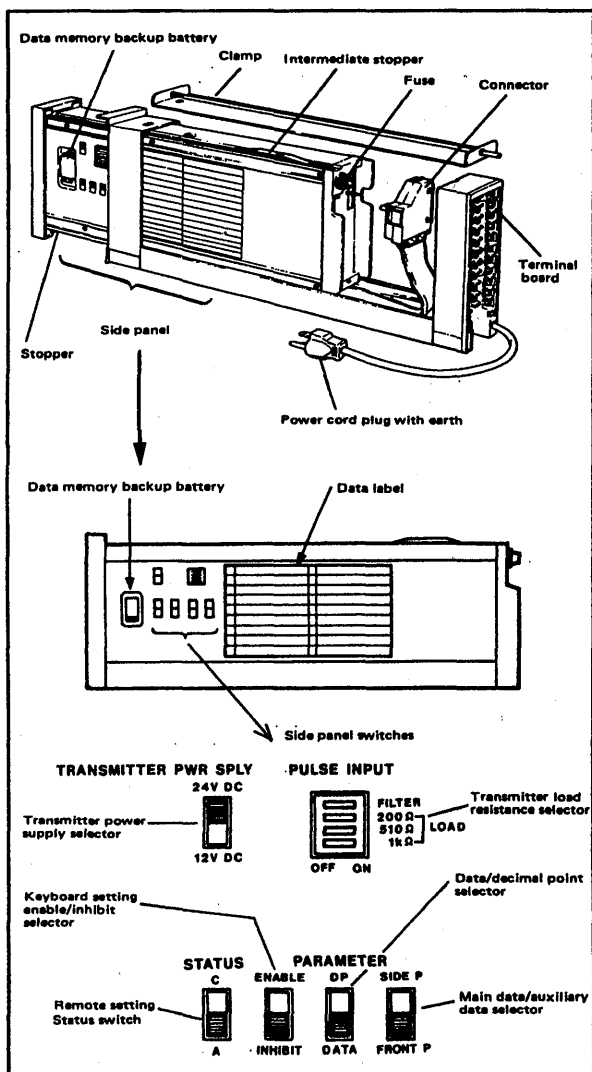

Figure 5-1-3. Functions of Data Display. (Auxiliary data display shown.)

- (5) Data display selector switch (▲, ▼).  
Used to select data to be displayed in the data display.
- (6) Main data list.  
Contains the most-often-used data. A desired data item can be selected using the data display selector switches.  
Main data:  
SUM ..... Flow totalizer value  
FLOW ..... Instantaneous flow
- (7) Selected-data lamps.  
One of these lamps lights to indicate the main data item selected by the data display selector switches.
- (8) Space for displaying coefficients and engineering units.  
The "coefficients/engineering units label" provided as an accessory is attached here.

**5-1-2. Instrument Side Panel.**

Figure 5-1-4 shows details of the instrument side panel.



**Figure 5-1-4. Details of Side Panel.**

- (1) Transmitter power supply selector switch (TRANSMITTER PWR SPLY).  
For pulse type process variable input signals (two-wire distributor type or three-wire distributor type, see Table 3-1-1, note \*1) 12 or 24 V DC is supplied from the STLD\*E unit, according to the switch setting.
- (2) Transmitter load resistance selector switch (PULSE INPUT).  
When a two-wire pulse transmitter is used with STLD\*E internal power supply distributor (see (1) above), the load resistance (200 Ω, 510 Ω or 1 kΩ) is selected by these switches. One of these switches turns the input filter On or Off.
- (3) C-A selector switch (STATUS).  
This switch causes "C" or "A" instrument status to be transmitted to a remote supervisory system, which should sense the status and enable or inhibit remote setting. For details of communications functions, refer to UFCH Field Control Unit Functions TI 34B6G1-01E.  
C: Status flag to enable setting by supervisory system.  
A: Status flag to inhibit setting by supervisory system.
- (4) Data setting enable/inhibit switch (ENABLE/INHIBIT).  
This switch is used to enable or inhibit data setting by the front panel switches.  
ENABLE: Data setting is enabled.  
INHIBIT: Data setting is inhibited.
- (5) Data/decimal point selector switch (D.P./DATA).  
This switch is used when setting the decimal point position of set data. With this switch set to DP, the decimal point can be set using the front panel switches (SHIFT and SET.)
- (6) Main data/auxiliary data selector switch (FRONT P./SIDE P.).  
This switch designates the data to be displayed on the front panel data display as either main data or auxiliary data.  
FRONT P.: Main data is displayed.  
SIDE P.: Auxiliary data is displayed.
- (7) Data label.  
The data label lists auxiliary data such as K factors and other computational constants, and function-specifying data.  
Write data values in the data field.  
Table 5-1-1 shows the data label, and Table 5-1-2 shows details of the auxiliary data function specification items (item nos. 21, 22 and 23).  
For further details, read TI 1B4E4-01E "Model STLD (Style E) Totalizer Functions and Data Setting". (2nd Edition or later).

Table 5-1-1. STLD Data Label.

STLD*E Totalizer		TAG No.	
01	Alarm (ALM) code		11
02	Flow totalizer value (uncompensated)		12
03	Flow totalizer value (compensated)		13
04	Cumulative totalizer value (uncompensated) *		14
05	Cumulative totalizer value (compensated) *		15
06	Flow totalizer reset command (enter 0 to reset)		16
07			17
08			18
09			19
10			20
21	Function specification (1)	-       -	41
22	Function specification (2)		42
23	Function specification (3)	-	43
24			44
25	Flow process variable span		45
26	Added/subtracted flow span		46
27	K factor for flow process variable		47
28	K factor for added/subtracted flow		48
29	K factor for repeater pulse		49
30	Totalizer scale factor		50
31	Analog display/flow signal repeater span *		51
32	Compensation reference temperature		52
33	Manual set temperature/Manual compensation coefficient		53
34	Maximum value of measured temperature/Maximum value of compensation coefficient		54
35	Minimum value of measured temperature/Minimum value of compensation coefficient		55
36	Compensation factor		56
37	Flow transmitter error compensation coefficient $\alpha$		57
38	First order compensation coefficient $\beta$ / density or specific gravity $\rho$		58
39	Second order compensation coefficient $\gamma$		59
40			* with added/subtracted flow signal

**Table 5-1-2. Function-Specifying Data.**

Note: Fill in the blanks of 21. Function specification (1), 22. Function Specification (2) and 23. Function specification (3) as follows:

Function specification (1) 

-	B	C	-	E	-
---	---	---	---	---	---

- B. Flow signal repeater pulse width**  
 0: Duty cycle 50% (for connection to YS-BCS Instrument)  
 1: 0.5 ms  
 2: 1 ms  
 3: 20ms  
 4: 33ms  
 5: 50ms  
 6: 100ms

- C: Communications write and keyboard setting enable/inhibit selector**  
 0: Enable/whole data  
 1: Inhibit/whole data  
 2: Enable/main data SUM aux. data No. 2 to 6, after No. 21  
 3: Inhibit/main data SUM aux. data No. 2 to 6, after No. 21

- E. Totalizer reset input**  
 0: Enable  
 1: Inhibit

Function specification (2) 

G	H	J	J	K	L
---	---	---	---	---	---

- G. Time unit of flow**  
 0: \*/h  
 1: \*/min  
 2: \*/day

- H. Flow signal/simulation specification**  
 0: Pulse flow signal  
 1: Analog flow signal  
 2: Simulation

- I. Added/subtracted flow signal**  
 0: Not provided  
 1: Provided, pulse, added  
 2: Provided, pulse, subtracted  
 3: Provided, analog, added  
 4: Provided, analog, subtracted

**J. Analog input signal processing**

	Low cutoff	Square root extraction
0:	1% or less	Not provided
1:	0% or less	Not provided
2:	1% or less	Provided
3:	0% or less	Provided

**K. Resetting of stored totalizer and repeater pulse values:**

- 0: All values reset.  
 1: Repeater and non-displayed totalizer digits preserved.  
 2: Like 1, but least-significant totalizer display digit also preserved.  
 3: Like 1, but two least-significant totalizer display digits also preserved.

**L.**

	Compensation computation provided for:	Process variable input	Added/subtracted input
0:	.....	Not provided	Not provided
1:	.....	Provided	Not provided
2:	.....	Not provided	Provided
3:	.....	Provided	Provided

Function specification (3) 

M	N	O	P	Q	-
---	---	---	---	---	---

**M. Compensation computation**

- 0: ASTM method  
 1: General quadratic formula  
 2: General compensation  
 3: Temperature-pressure compensation, natural gas  
 4: Temperature-pressure compensation, steam (weight)  
 5: Temperature-pressure compensation, steam (heat quantity)  
 6: Temperature-pressure compensation, general gas (deviation coefficient K)  
 7: Temperature-pressure compensation, general gas (compressibility factor z)

**N. Temperature/compensation coefficient and pressure data**  
 [ASTM method, general quadratic formula or general compensation]

	Temperature (or compensation input)
0:	Process variable
1:	Manual set value

[Natural gas or general gas]

	Temperature	Pressure
0:	Process variable	Process variable
1:	Manual set value	Process variable
2:	Process variable	Manual set variable
3:	Manual set value	Manual set value

[Steam]

	Temperature	Pressure	Priority
0:	Process variable	Process variable	Pressure
1:	Manual set value	Process variable	Pressure
2:	Process variable	Manual set value	Temperature
3:	Manual set value	Manual set value	Pressure

**O. Temperature unit**

- 0: °C  
 1: °F

**P. Pressure unit**

- 0: psia  
 1: psig  
 2: kgf/cm<sup>2</sup> abs  
 3: kgf/cm<sup>2</sup> G  
 4: MPa abs  
 5: MPa G

**Q. Selection of ASTM compensation equation**  
 (Effective when M=0 in function specification (3))

- 0: Old ASTM (ASTM-52)  
 1: New ASTM (ASTM-80, ISO 91/1) Crude Oil  
 2: New ASTM (ASTM-80, ISO 91/1) Fuel Oil  
 3: New ASTM (API, ISO) Lubricating Oil

Supplement for steam

When steam temperature and pressure compensation computations are carried out in Item 23, function specification (3) M :

In compensation expression 4 (temperature and pressure compensation, steam (in kg)) or 5 (temperature and pressure compensation, steam (in calorie)), items and contents described below are changed.

Item No.	Contents	Description
25	Flow process variable span	Use kg/h or lb/h etc. for units setting.
26	Added/subtracted flow span	
31	Analog flow rate display/ flow signal repeater span	When calories are measured in Item 23 (3), use 10 <sup>3</sup> Kcal/* in units.
32	Compensation reference temperature	Be sure to set. When L:0 is specified in Item 22, this value is used for computation.
36	Compensation factor	Displayed in $\gamma/\gamma b$ (kg) and $\gamma h/\gamma hb$ (calories). $\gamma b$ : Compensation reference specific weight $hb$ : Compensation reference specific enthalpy
41	Compensation reference pressure	Be sure to set. When L:0 is specified in Item 22, this value is used for computation.
45	Atmospheric pressure	
58	Compensation reference specific weight $\gamma b$	(New item) Displays data used for compensation computation.
59	Compensation reference specific enthalpy $hb$	
02	Flow totalizer value (uncompensated)	Totalizer value is displayed in units (kg and calories) set in Item 04.
03	Flow totalizer value (compensated)	
04	Cumulative totalizer value (uncompensated)	
05	Cumulative totalizer value (compensated)	



Main data display	Contents	Description
SUM	Totalized flow value (with two-input adding/subtracting and compensation)	Displayed in units (kg or calories) set in Item 04.
FLOW	Instantaneous flow	

For steam temperature and pressure compensation (analog input), the following two equations are provided.

(1) For linear input:

$$W = W_b \times \gamma / \gamma_b$$

(2) For differential pressure input:

$$W = W_i \sqrt{\Delta p} \times \sqrt{\gamma / \gamma_b}$$

where W: Gravimetric flow

W<sub>b</sub>: Compensation reference gravimetric flow

W<sub>i</sub>: Gravimetric flow input span

Δp: Differential pressure input

γ: Specific weight

γ<sub>b</sub>: Compensation reference specific weight

For more information, see TI 1B4E1-01E.

<Note> Set engineering units of pressure and temperature shown in

Item No. 23-0 and P. When data of pressure and temperature are set in other than Item No. 23-0 and P, the least significant digit of the data may change by 1 because of unit conversion performed in the CPU.

Pressure parameters must be set in 4 digits.

(ex. 1: 0.000 kgf/cm<sup>2</sup>G), (ex. 2: 14.69 psia).

### 5-2. Preparation of Data Label.

Before using the STLD\*E totalizer, the required values of auxiliary data items — such as function specifying data, K factors and other computational constants — must be decided and input, and these values should also be written on the data label (see note).

For further details, read TI 1B4E4-01E “Model STLD (Style E) Totalizer Functions and Data Setting”. (2nd Edition or later).

**NOTE**

If option/DL is specified at order time, the factory will write data values on the data label before shipping the totalizer.

### 5-3. Preparation for Operation.

Perform preparation with the totalizer installed in the panel, or removed and placed on a work table. (Suppose that the instrument module is in the housing).

Removing the instrument module from the housing:

- ① Push up the stopper, located below the front panel of the instrument module, to remove it. When it is drawn out halfway, the instrument module is stopped by an intermediate stopper. (Figure 5-3-1).

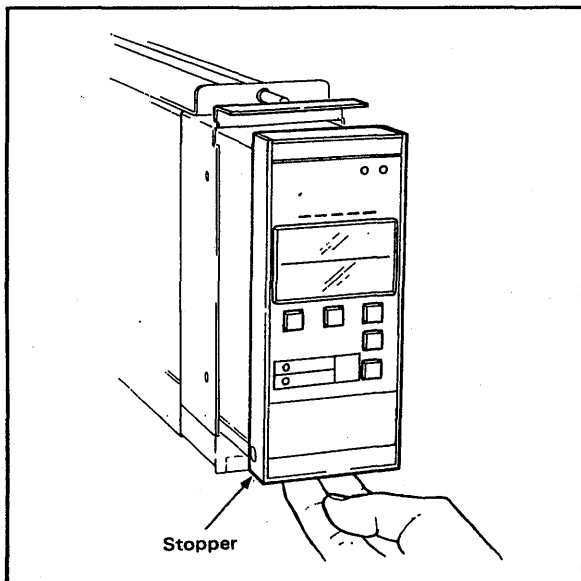

Figure 5-3-1. Removing Instrument Module.

- ② To remove the instrument module from the housing, push down on the intermediate stopper while pulling the instrument out of the housing as shown in Figure 5-3-2.

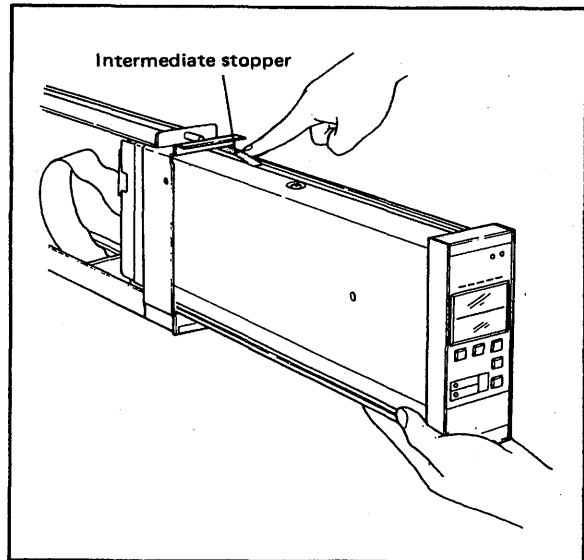

Figure 5-3-2. Removing Instrument Module.

- ③ Detach the connector from the instrument module. The instrument module is now separated from the housing. (Figure 5-3-3).

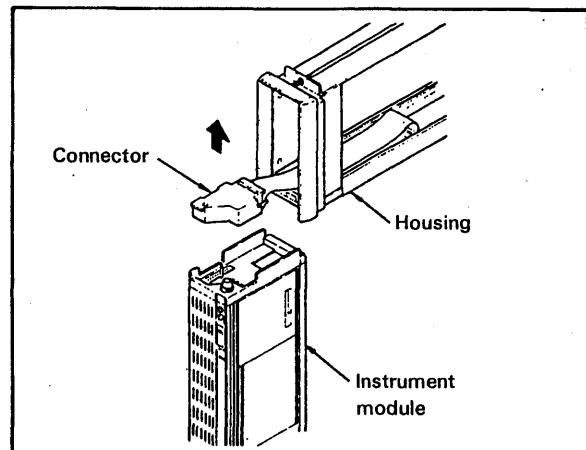

Figure 5-3-3. Detaching the Connector.

#### 5-3-1. Check Special Parts are Installed.

Check to see that the fuse and data memory backup battery are installed. If not, refer to Chapter 6 “Maintenance” for installation procedure.

#### 5-3-2. Setting Side Panel Switches.

- (1) Transmitter power supply selector switch (TRANSMITTER PWR SPLY).

For pulse type process variable input signals (two-wire distributor type or three-wire distributor type, see Table 3-1-1, note \*1) a distributor in the STLD\*E unit supplies 12 or 24 V DC.

The switch setting is irrelevant for two-wire voltage level or contact pulse inputs (left side of Table 3-1-1, note \*1).

(2) Transmitter load resistance selector switch (PULSE INPUT).

- When using a two-wire pulse transmitter with the distributor in the STLD\*E unit, the switch corresponding to the desired load resistance should be turned ON. When using any other type of transmitter, be sure to turn all of the resistance switches OFF.
- If input filtering is needed, turn the FILTER switch ON. For repeater pulse input from YEW-SERIES BCS instrument, be sure to turn the input FILTER switch OFF.

NOTE

Select an appropriate time-constant from zero (0) to 9999 seconds and set it into the auxiliary data items 17 and 18 "Pulse Input Filter", when the displayed value of instantaneous flow (or analog flow repeater signal) wavers owing to the irregularity of input pulse signal.

As for setting operation to instrument, refer to Chapter 5-3-4 (Setting Auxiliary Data).

(3) Communications write-inhibit switch (STATUS C/A selector switch).

The switch to transmit whether the totalizer is in C-status or not to a supervisory system.

C: Status to enable setting by a supervisory system.

A: Status to disable setting by a supervisory system.

(4) Data setting enable/inhibit switch (ENABLE/INHIBIT)

Set this switch to INHIBIT during normal operation.

(5) Data/decimal point selector switch (D.P./DATA).

Set this switch to DATA during normal operation.

Set this switch to D.P. when decimal point is to be set.

(6) Main data/auxiliary data selector switch (FRONT P./SIDE P.)

Set this switch to FRONT P. (main data) during normal operation. Set this switch to SIDE P. when auxiliary data is to be set.

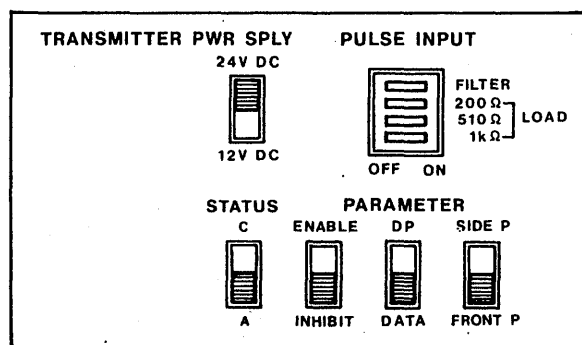

Figure 5-3-4. Side Panel Switches.

5-3-3. Setting Main Data

The main data of this totalizer is totalized flow (SUM) and instantaneous flow (FLOW), and no data setting is needed.

5-3-4. Setting Auxiliary Data.

As described below, the auxiliary data values must be set to correspond with the data on the data label prepared in section 5-2:

NOTE

If this controller has been ordered with data label (option /DL), the data has already been set at the factory according to the data label prepared by YOKOGAWA.

Before starting operation, be sure to check that each data item has been set correctly (to correspond with the label).

If any error is found, correct the data setting as explained below.

NOTE

Auxiliary data should be set in the sequence items 21 thru 57 and items 04 thru 18.

(1) Setting the decimal point.

Set the main data/auxiliary data selector switch on the side panel to SIDE P. (auxiliary data) position, set the data/decimal point selector switch to the DP position, then set the data setting enable/inhibit switch to ENABLE. Using the data display selector switches  $\blacktriangle$   $\blacktriangledown$ , select the data whose decimal point is to be set, and display it on the lower section of the display. Next perform the following operations:

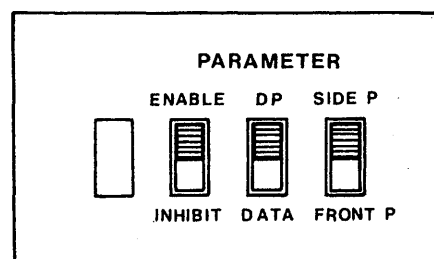

Figure 5-3-5.

[Decimal point position setting example]

Switch operation	Display (lower)	Description
		The data and decimal point of the currently displayed parameter are displayed.
SHIFT ▶	(Note 1) 	The decimal point of the currently displayed parameter flashes.
SHIFT ▶		When the SHIFT switch is held depressed, the decimal point position changes digit by digit and the decimal point position flashes. When the decimal point reaches the desired position, release the switch.
SET	(Note 2) 	The entire display flashes.
SET		Decimal point setting completed.

Note 1: The \* mark indicates a flashing decimal point.  
 Note 2: The shaded portion indicates flashing digit.

(2) Setting data.

Set the side panel main data/auxiliary data selector switch to SIDE P. (auxiliary data); set the data/decimal point selector switch to DATA, and set the data setting enable/inhibit switch to ENABLE. Then select the data item to be set and display it on the lower display section using the data display selector switches ▲▼. Next set the data as described below.

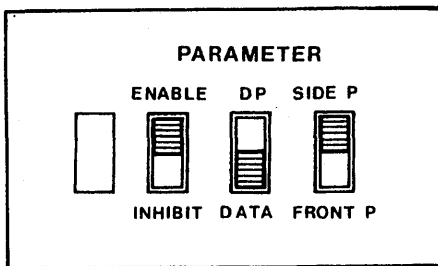

Figure 5-3-6.

After completing data setting, set the data setting enable/inhibit switch to INHIBIT so as to prevent accidental (erroneous) setting.

Unused auxiliary data

Auxiliary data that is not being used — according to the function specification — is skipped.

[Example of display and setting]

Switch operation	Display (lower)	Description
		The current set value is displayed.
SHIFT ▶	(Note) 	The most significant digit that may be set flashes.
INCR ▲		Set the desired data. If setting is not needed, go to the next step.
SHIFT ▶		The next most significant digit flashes.
INCR ▲		Set the desired data. If setting is not needed, go to the next step.
INCR ▲		Repeat the above setting operation to the least significant digit.
SET		The whole data thus set flashes.
SET		Data setting is completed.

Note: The shaded portion indicates flashing of data display.

5-3-5. Simulation.

After completing data setting, check the operation of this totalizer using its simulation function.

Set auxiliary data item 22 [function specification (2)] H Process variable flow signal/simulation specification to simulation mode, and check the totalizer operation.

The measurement input that is 75% of the span is generated inside the instrument. Accordingly, totalizing operation is continued as if an input of 75% of the span is being applied.

Table 5-3-1. Auxiliary Data Simulation Specifying Item.

18. Function specification (2)
H Process variable flow signal/simulation specification
0: Pulse flow signal
1: Analog flow signal
2: Simulation

**5-3-6. Other Preparations.****(1) Attach coefficient/units label.**

Choose suitable coefficient and engineering units labels from those supplied with the totalizer, and stick them in the appropriate space on the front panel. (See Figure 5-3-7.)

If a suitable label is missing, use a blank label and write the necessary coefficient or units on it.

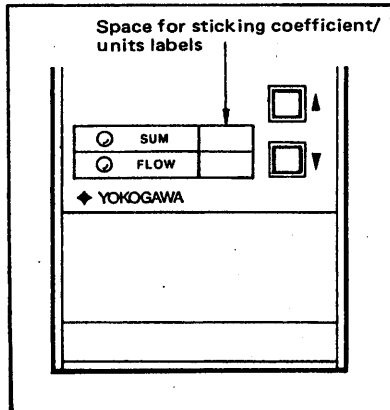

Figure 5-3-7.

**5-4. Operation.**

After setting the auxiliary data, apply an input to the totalizer. It will start totalizing, and indicate the totalized value on the display.

To reset the totalized value, turn the reset status input ON\* or enter 0 in auxiliary data 06 (flow totalizer reset command).\*\*

**Note:**

\* The RESET status input uses non-locking contact which is "reset" in the ON state (minimum ON time at least 220 ms).

\*\* "1" is displayed when flow measurement values (main data SUM, auxiliary-data 02 and 03) are totalized. Enter 0 to reset the current totalizer data (cumulative totalizer value cannot be reset).

**5-4-1. Resetting totalizer value.**

This totalizer value contained in auxiliary data items 04 and 05 are not reset by the reset signal. To reset this value, set this auxiliary data to zero using the data setting switches. For the setting procedure, refer to 5-3-4 "Setting of auxiliary data".

**5-5. Action to be Taken when FAIL or ALM Lamps Light.**

Any faults in the totalizer or in the signal connections are indicated by the FAIL or ALM lamps lighting. If either of these lamps lights (or begins flashing), please take appropriate action (as described below) without delay.

**5-5-1. Action to be Taken when FAIL Lamp Lights.**

- (1) Set the main data/auxiliary data selector switch to the auxiliary data position to indicate the alarm (ALM) contents of auxiliary data item 01 on the data display, and check the cause of the fault. (See Figure 5-5-4). Take appropriate action to correct the fault.
- (2) If the data display does not function normally, it can be presumed that the microprocessor is not operating.

**5-5-2. Action to be Taken when ALM Lamp Lights.**

The ALM lamp lights if the high or low limit alarms of the totalizer operate, or when input-output signals are disconnected.

Display the alarm (ALM) contents of auxiliary data item 01 on the data display, and examine the cause of the fault. (See 5-5-4.) Take appropriate action corresponding to the cause of the fault.

**5-5-3. Action to be Taken when ALM Lamp Flashes.**

The ALM lamp begins flashing if the voltage of the data memory backup battery is low. Replace the battery with a new one. (See section 6-3 for replacement procedure.)

**NOTE**

- (1) If the ALM lamp begins to flash during normal operation, replace the battery within one month.
- (2) The flashing of the ALM lamp has precedence over its continuous lighting. Thus, other alarms cannot be displayed while the lamp is flashing.

**5-5-4. Alarm (ALM) Codes, their Meanings and Control Actions when Abnormal**

The alarm codes and their meanings are listed below.

Code	Lamp	Meaning	Control actions when abnormal
00000	—	Normal	—
—	FAIL	Fault in CPU.	FAIL contact: Open
00001	FAIL	Fault in A/D converter.	
00002	FAIL	Fault in D/A converter.	
00004	ALM	Computation range overflow.	Computation using limit value.
00008	ALM	Temperature input/compensation coefficient input signal out of range.	Computation using manual set value/manual compensation coefficient.
00010 (note)	ALM	Error in compensation computation.	<ul style="list-style-type: none"> <li>• Computation is performed with limit value.</li> <li>• Control is continued.</li> </ul>
00020	ALM (flashing)	Data memory backup battery not installed, or low battery voltage.	Operates normally unless power failure occurs.
00080	ALM	RAM memory data initialization.	Computation using limit value.
00100	ALM	Process variable input signal out of range.	Computation using limit value.
00200	ALM	Added/subtracted input signal out of range.	
00800	ALM	Flow signal out of range (for analog display and flow signal repeater span) after addition/subtraction.	
02000	ALM	Repeater internal data overflow.	
04000	ALM	Data setting out of range.	
10000	ALM	Pressure input signal out of range.	Computation using manual set value.
20000	ALM	Supersaturated steam.	Computation regarding as saturated steam.
40000	ALM	Pressure out of compensation range.	Computation using limit value.
80000	ALM	Temperature out of compensation range.	Computation using limit value.
P.Error	ALM	Supply voltage too low.	Operation stops.

**Note:**

In the computation of basic equation (see page 2-2) of volume conversion coefficient, if  $|\alpha\gamma\Delta t| > 0.5$ , "0010" alarm occurs.

At this time, computation is continued with the value limited at 0.5 or -0.5. This processing is executed to prevent the internal data overflow if improper input or set value is applied.

If two or more faults occur simultaneously, the hexadecimal sum of their code numbers is displayed.

[Example]

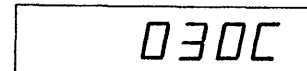

030C = 0004 + 0008 + 0100 + 0200 (computation range overflow, temperature input/compensation coefficient input signal out of range, process variable input signal out of range, added subtracted input signal out of range).

The diagnostic alarm code display reverts to zero and the ALM lamp turns off when the cause of the fault is removed, except for the following items.

Select these items using the data selector switches and reset them using the **SET** key.

The items to be reset by the **SET** push button switch.

- RAM memory data initialization.
- Repeater internal data overflow.



## 6. MAINTENANCE.

This chapter explains the indicator adjustment and parts replacement procedures.

### 6-1. Replacing Nameplate (Tag Label).

Draw out the instrument module a little from its housing, and open the lid located on the top of the front panel. Remove the nameplate, and install a new one. (Figure 6-1-1).

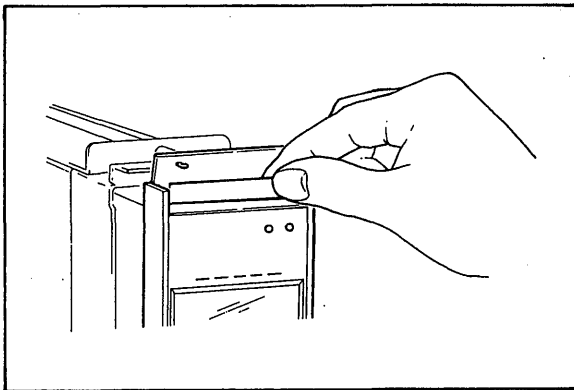

Figure 6-1-1. Replacing Nameplate.

### 6-2. Replacing Fuse.

If it seems that the fuse may be faulty, check the inside of the fuse holder for contamination or poor contact with fuse.

Recommended replacement interval: About 3 years.

- (1) To remove the fuse, unscrew the fuseholder cap (turn it in the direction of the arrow marked on the cap — counterclockwise); the cap and fuse may then be removed.
- (2) Install a new fuse of the correct rating. Tighten the cap firmly.

Note: Use the dedicated fuse (S9510VK). Do not use a fuse for other products.

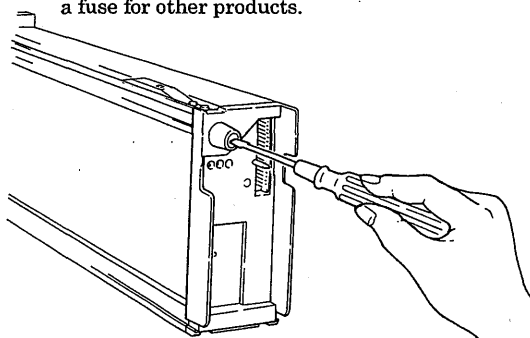

Fuse Part No : S9510VK  
Rating : 1A

Figure 6-2-1. Replacing Fuse.

### 6-3. Replacing Data Memory Backup Battery.

If the ALM lamp on the front panel of the instrument begins flashing, please replace the battery without delay.

Recommended replacement intervals:

About 5 years (charging, at ambient temperatures below 45°C)

About 1 year (shelf-life, at ambient temperatures below 45°C)

**NOTE**

Leave power applied to the instrument while replacing the battery. If the battery is removed while the power is off, data (parameter) settings may be lost.

- (1) Draw out the controller module a little from the housing, and remove the battery cover and battery. (See Figures 6-3-1 and 6-3-2.)
- (2) Install a new battery, and fit the battery cover securely.
- (3) Make sure that the ALM lamp on the front panel has stopped flashing.

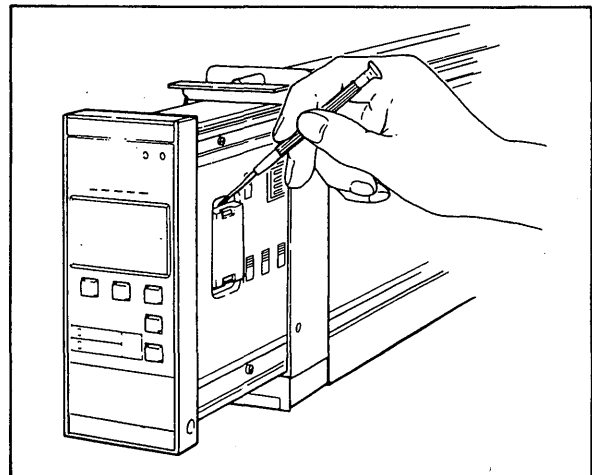

Figure 6-3-1. Removing Battery Cover.



**[Precautions for storage and handling of data memory backup batteries]****(1) Storage conditions**

Ambient temperature: -10 to 60°.

Ambient humidity: 5 to 95% RH (non-condensing).

Location free from corrosive gases.

**(2) Replace the complete battery assembly (battery in plastic plug-in package).****(3) When measuring the battery voltage, be sure to use a high impedance voltmeter. Do not attempt to measure the voltage using a circuit tester or the like.****(4) Cautions in handling batteries**

- Do not charge the batteries.
- Do not heat or put into a fire.
- Do not short the positive and negative poles together.
- Do not apply shock, do not attempt to disassemble.

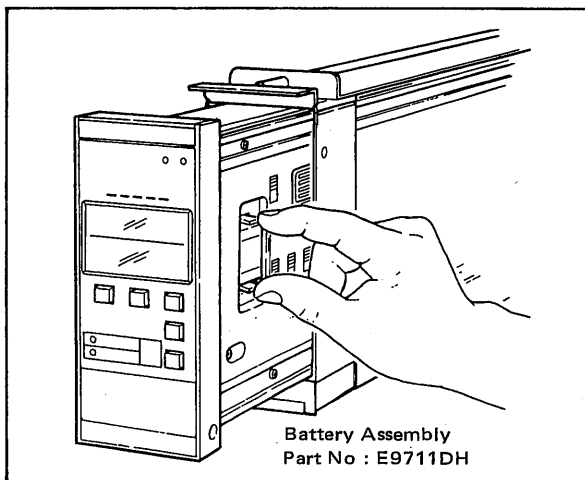

**Figure 6-3-2. Removing Battery.**

# YEW SERIES BCS STLD\* E TOTALIZER DATASHEET

Spec. No.			
YOKOGAWA Order No.	SEC.	Loop	Item
Instrument No.			
Model and Suffix Codes STLD-			

Customer:

Equipment:

STLD*E Totalizer		TAG No.										
01	Alarm (ALM) code			11								
02	Flow totalizer value (uncompensated)			12								
03	Flow totalizer value (compensated)			13								
04	Cumulative totalizer value (uncompensated) *			14								
05	Cumulative totalizer value (compensated) *			15	Measured pressure							
06	Flow totalizer reset command (enter 0 to reset)			16	Measured temperature/compensation coefficient input							
07				17	Measured pulse input filter							
08				18	Added/subtracted pulse input filter				S			
09				19								
10				20								
21	Function specification (1)	-	-	41	Compensation reference pressure							
22	Function specification (2)			42	Manual set pressure							
23	Function specification (3)			43	Maximum value of measured pressure							
24				44	Minimum value of measured pressure							
25	Flow process variable span			45	Atmospheric pressure							
26	Added/subtracted flow span			46	Specific gravity							
27	K factor for flow process variable			47	CO <sub>2</sub> mol % Mc				%			
28	K factor for added/subtracted flow			48	N <sub>2</sub> mol % Mn							
29	K factor for repeater pulse			49	Supercompressibility factor Fpv							
30	Totalizer scale factor			50	Dryness							
31	Analog display/flow signal repeater span *			51	Specific weight $\gamma$							
32	Compensation reference temperature			52	Specific enthalpy h							
33	Manual set temperature/Manual compensation coefficient			53	Deviation factor K							
34	Maximum value of measured temperature/Maximum value of compensation coefficient			54	Critical temperature Tc							
35	Minimum value of measured temperature/Minimum value of compensation coefficient			55	Critical pressure Pc							
36	Compensation factor			56	Critical compensability factor Zc							
37	Flow transmitter error compensation coefficient $\alpha$			57	Humidity compensation coefficient							
38	First order compensation coefficient $\beta$ / density or specific gravity $\rho$			58	Compensation reference specific weight $\gamma_b$							
39	Second order compensation coefficient $\gamma$			59	Compensation reference specific enthalpy hb							
40				* with added/subtracted flow signal								
$\Delta$	NO.	Revised by	CH.	CH.	K	USER		D		E		K
$\Delta$	/	/	/	/	/	DR.	CH.	DR.	CH.	DR.	CH.	
$\Delta$	/	/	/	/	/							
$\Delta$	/	/	/	/	/							



# Customer Maintenance Parts List

Model STLD (Style E)  
Totalizer

YEW SERIES 80

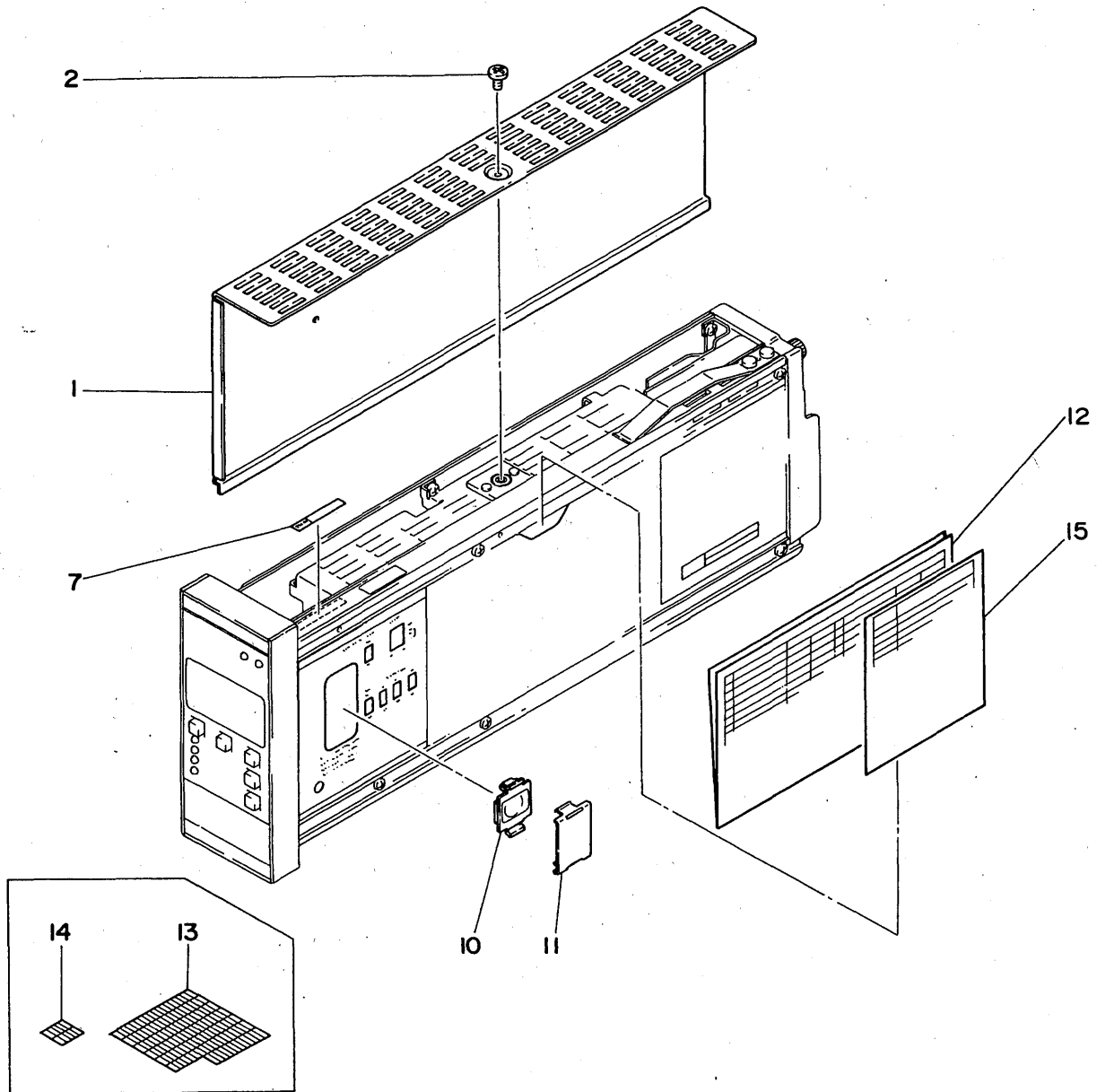

Item	Part No.	Qty	Description
1	E9711TG	1	Cover
2	Y9405LB	1	B.H. Screw, M4 x 5
7	Y9422NP	1	Tag No. Label (blank)
10	E9711DH	1	Battery Assembly
11	E9711GQ	1	Cover
12	E9714RL	1	Data Label
13	E9712DL	1	Label
	E9712EF	1	Label (for use in Japan only)
14	E9712DS	1	Label (blank)
15	E9714RP	1	Alarm Code Sheet

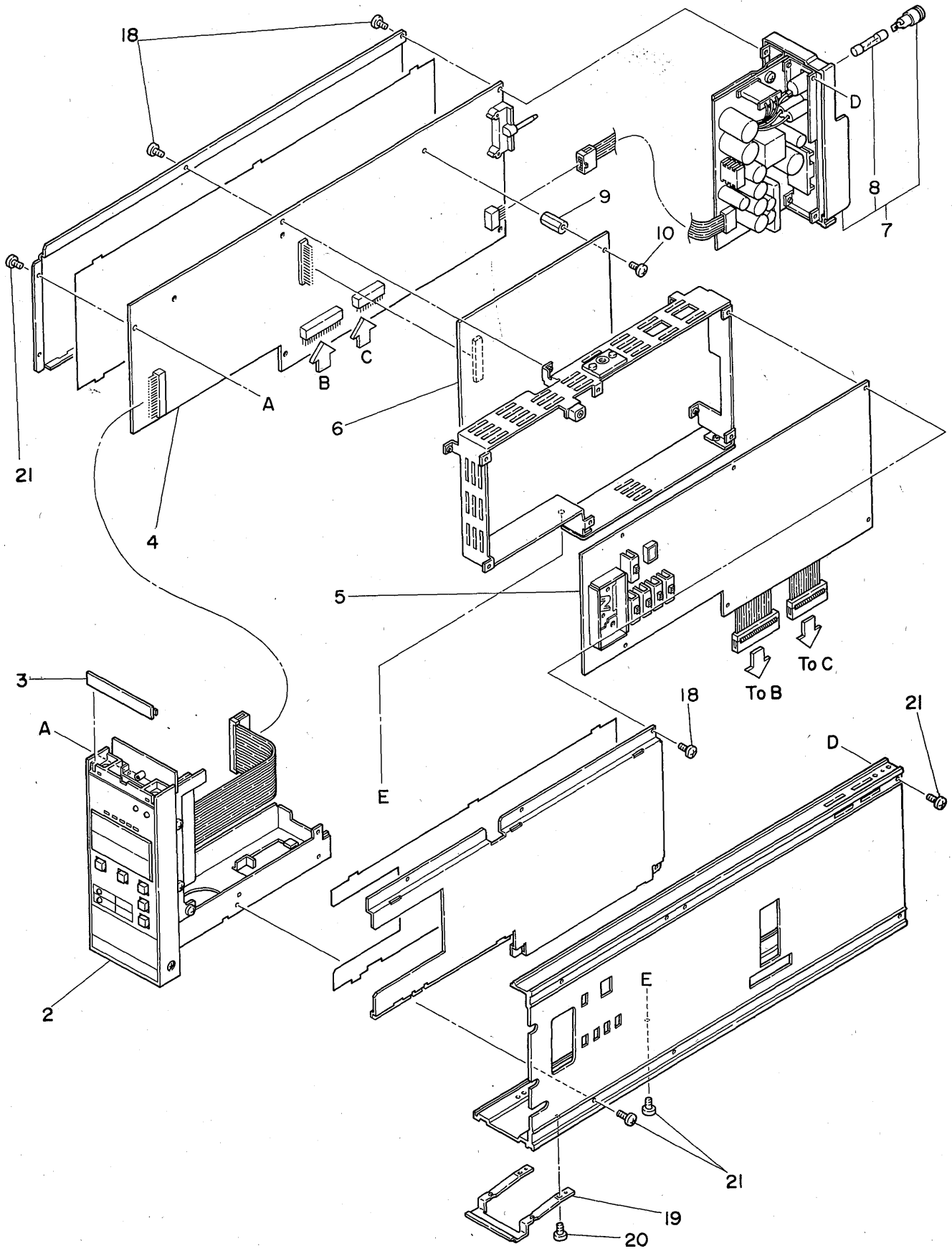

Item	Part No.	Qty	Description
2	—	1	Display Assembly (see page 4)
3	E9711FG	1	Plate (blank)
—	—	1	Control Assembly (item 4 through 18)
4	E9714TD	1	I/O Card
5	E9714WD	1	CPU Card
6	E9714XA	1	Option Card (for Model STLD-20□*E)
	E9714XB	1	Option Card (for Model STLD-30□*E/PA)
	E9714XC	1	Option Card (for Model STLD-30□*E/PD)
7	E9716YB	1	Power Supply Unit (for 100 V version)
	E9716YS	1	Power Supply Unit (for 220 V version)
8	S9510VK	1	Fuse — "1A"
9	T9008ZB	2	Stud
10	Y9306JB	4	Pan H. Screw, M3 x 6
18	Y9306JB	12	Pan H. Screw, M3 x 6
19	E9711TD	1	Stopper
20	E9711TE	2	Screw
21	Y9306JB	10	Pan H. Screw, M3 x 6

} Expect for Model STLD-10□\*E

### Display Assembly

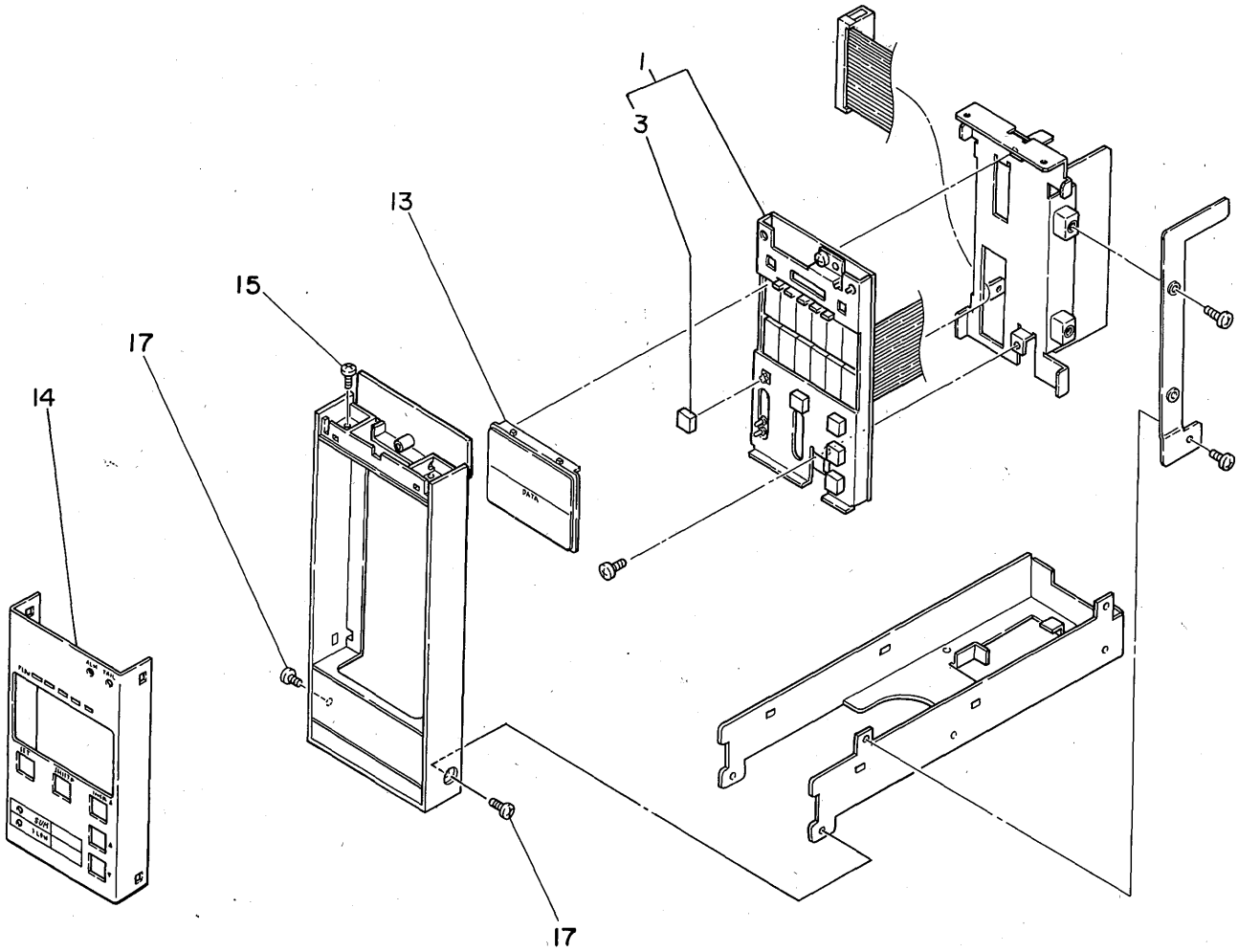

Item	Part No.	Qty	Description
—	E9714GE	1	Display Assembly (item 1 through 15)
1	E9714PG	1	Display Card Assembly
3	E9712CC	5	Key Top
13	E9711GH	1	Cover
14	E9711HE	1	Bracket
15	Y9306JB	2	Pan H. Screw, M3 x 6
17	Y9306JB	2	Pan H. Screw, M3 x 6

# Instruction Manual

## / HTB Power Supply Terminal Connections for Panel - mounted Instruments (Option)

### 1. GENERAL.

If you specify the terminal board to which the power source is directly connected (suffix code / HTB), the external wiring to the terminal board is necessary.

### 2. APPLICABLE INSTRUMENTS.

Model	Description
SRVD	Strip Chart Recorder
SIHM	Indicator (With Housing)
SIHF	Bar Graph Indicator (With Alarms)
SIHK	Indicator (With Alarms)
SLCD	Indicating Controller
SLPC	Programmable Indicating Controller
SLMC	Programmable Indicating Controller with Pulse → Width Output
SMLD	Manual Station
SMST	Auto/Manual Station
SMRT	Ratio Set Station
SCMS	Programmable Computing Station
SBSD	Batch Set Station
SLCC	Blending Controller
SLBC	Batch Controller
STLD	Totalizer

### 3. NAME OF COMPONENTS AND TERMINAL DESIGNATION OF POWER SUPPLY

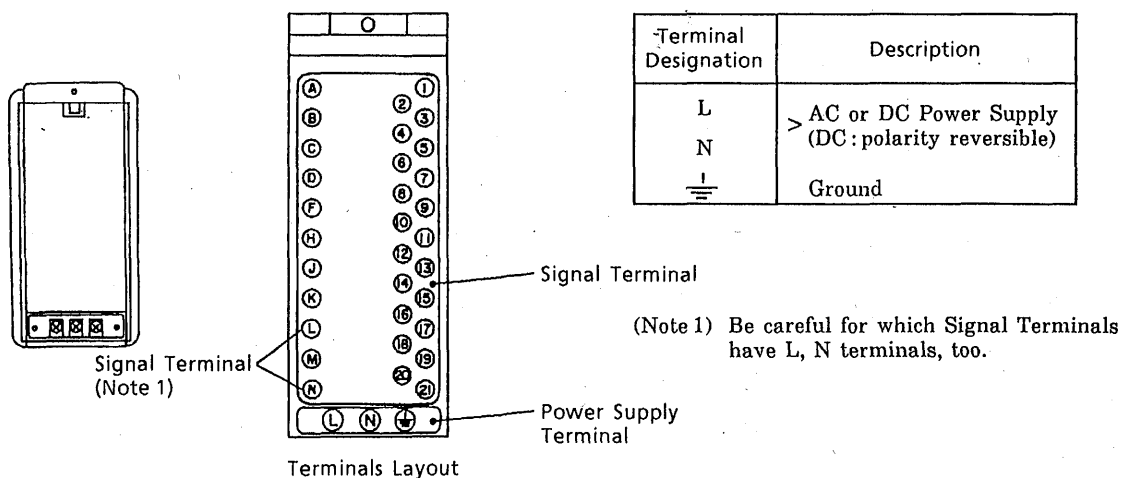

### 4. POWER SUPPLY AND GROUND WIRING.

- (1) All cable ends must be furnished with crimp-on type solderless lugs (for 4mm screw).
- (2) Examples of applicable cables.

Cross-sectional area of the cable conductor : 2.0mm<sup>2</sup>.\*

Note \* : Power supply cables should be determined from the instrument power consumption - they must have conductors with cross-sectional area of at least 1.25mm<sup>2</sup>.

Applicable cable : 600V vinyl insulated cable (IV), conforming to JIS C3307.

Vinyl sheathed cables for electric appliances (KIV), conforming to JIS C3316.

- (3) After completing the power supply and ground wiring, mount the power terminal cover.